

Drawing property of IKG. Is not possible reproduced or made public it without authorization of IKG

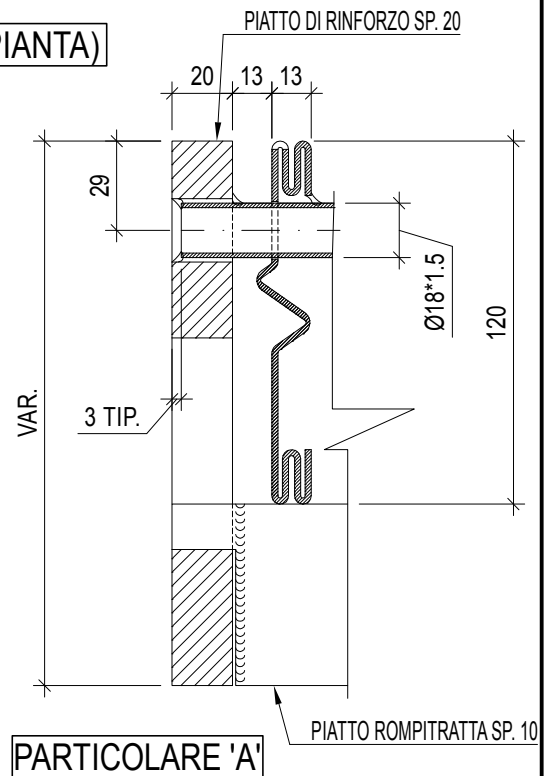
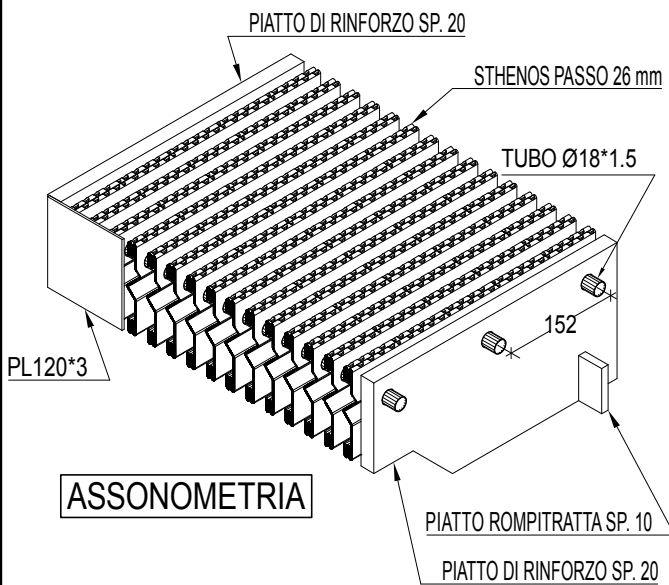
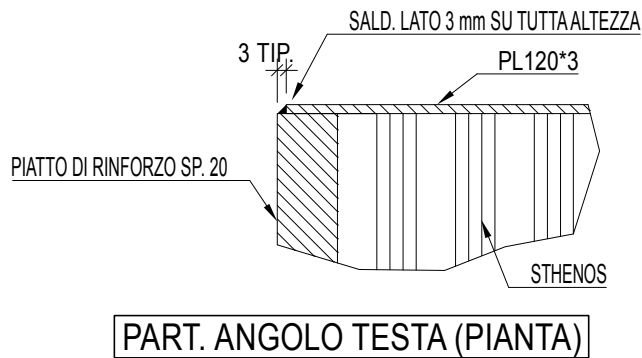
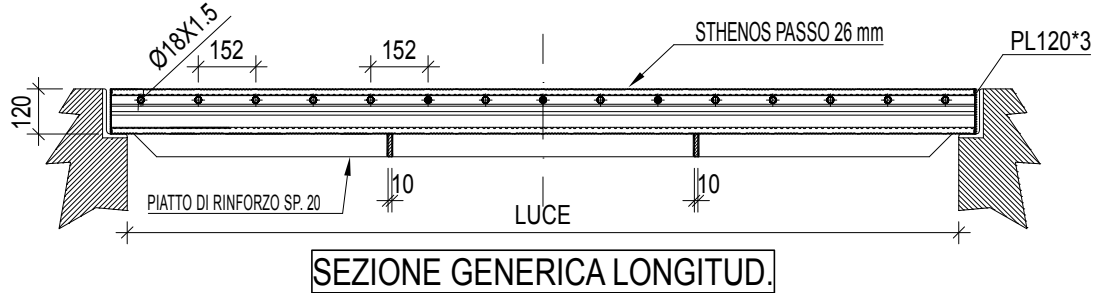
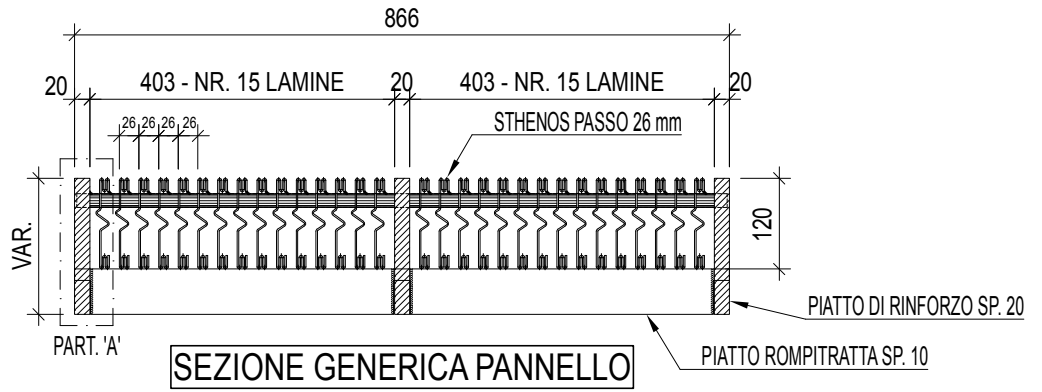

TITOLO

GRIGLIATO STHENOS RINFORZATO - DETTAGLI
STHENOS GRATING REINFORCED - DETAILS

	FIRMA	DATA
DISEGNATO	DA	03.01.2017
CONTROLLATO	DA	03.01.2017
VISTO	SL	03.01.2017

DISEGNO NR.	REV.
NOR - STHE - 003	0
CONTINUA SU:	03.01.2017